

## **Fabricated Prototype of Raised-Bed Planter for Wheat**

**Awad, M. A.**

**Researcher in Agric. Eng. Res. Institute, A.R.C, Giza, Egypt**



### **ABSTRACT**

A bed-former-planter has been fabricated in order to overcome the shortage of appropriate machinery to practice the raised-bed technology for wheat sowing in Egypt. The fabricated planter consists of a frame, seed hoppers, precision metering device, bed former, and power transmission system. It is mounted machine, that supplied it's draft requirement from a tractor while; the drive to seed metering mechanism is transmitted from ground drive wheel through chain and sprockets. The fabricated planter is capable to perform two wheat sowing modes, namely: - sowing seeds on pre-established broad beds, and sowing seeds while simultaneously establishing beds. The performance of fabricated planter was tested under the following variables: Average of four travel speeds (0.76, 1.08, 1.21 and 1.46 m/s); three-disc cells capacities (6, 8, and 10 seeds per cell); and the two available wheat sowing modes. The evaluation of the fabricated planter was investigated by taking into consideration the machine mechanical performance, and the wheat growth aspects. The mechanical performance was evaluated in terms of machine power requirements, specific energy consumption, and machinery cost. while, the wheat growth aspects were evaluated in terms of the seed hills number, germination ratio and grain yields (ton/fed). The data evaluated the fabricated planter performances, revealed, that the best planting performance was accomplished using forward travel speed of 1.21m/s, and metering cell capacity of (8 seeds). Whereas, under these operating conditions lower energy consumption of 3.01 KW.h /fed, higher grain yield of 2.9 (ton/fed), machinery cost of 59 LE/fed and higher germination ratio of 97.78% % were achieved compared to the other investigated operational parameters.

### **INTRODUCTION**

Wheat is not only the most important cereal crop in the world but also it is the important strategic food crop for the people of Egypt. UNDP (2013) reported that wheat as a winter crop is usually planted either by drilling the seed in rows while maintaining a row-to-row distance of 15cm or by manual broadcasting the seed on a leveled soil flat surface and then incorporating it by shallow tillage following planting and flood irrigation, especially in irrigated areas. In collaboration with partners from Agricultural Research Center (ARC), National Water Research Center (NWRC), and scientists from ICARDA conducted research on modifying the local grain drills with an affordable multi-crop raised-bed unit for small to medium sized farms. The modified local grain drill was used to establish broad bed with appropriate width and height while simultaneously sowing seeds on those beds A crop production package was introduced comprising early maturing varieties, efficient water use cultivars with intercropping systems (where applicable), crop health and fertilization regime, and improved management practices.

Atef Swelam (2015) developed and locally manufactured raised-bed machine for small-scale farms to improve water productivity in the Nile Delta of Egypt. He indicated that the developed machine has enabled the farmers to achieve remarkable results that include around 25% saving in applied water, around 50% reduction in seed rate, around 25% decrease in farming cost, around 30% increase in fertilizer use efficiency, and around 15-25% increase in crops yields.

In bed planting systems, wheat crop is sowed on the raised beds in ridge-furrow system. This system is often considered more appropriate for growing high value crops that are more sensitive to temporary water logging stress. Moreover, that system of raised bed planting of crops may be particularly advantageous in areas where groundwater levels are falling and

herbicide-resistant weeds are becoming a problem. Wheat yields improved by 10% with the proper variety, production costs can fall by 20 to 30%, and irrigation water requirements can be reduced up to 35% compared to conventional planting on the flat soil [Wang Fahong *et al* (2004) and Roth *et al* (2005)]. Tanveer *et al* (2003) observed that weed infestation was reducing if wheat is planting on raised beds and improves soil fertility and structure, reduces soil erosion, water requirement and cons port several crops in complex relays or intercropping and rotation.

Jat *et al* (2004) reported that due to uniform planting distribution cross sowing reduced weed growth rate and increased yield and its attributes. They added that, farmers tended to sowing wheat in hills on ridges Whereas, Hussein *et al* (2006) studied five sowing methods [broadcast, line, cross (20x20 cm), ridge 60 cm and ridge 70 cm] they concluded that planting wheat in hills on two sides of ridge 60 cm or in cross sowing methods produce the highest grain yield.

Abou-Sabe (1956). Satoshi *et al*. (2000) studied the effects of seed number on yield and yield components and found that when the seed number increases, panicle number per square meter raises significantly and the seed number per panicle falls indicating the reversible nature of these two characteristics. The results of this experiment demonstrated the positive effects of seed number per panicle on yield making up for the decreasing panicle number. Lack. Sh (2012) Studied the effects of seed number per hill on the yield (2, 4, 6 and 8) and he found that the highest yield was obtained from 6 seeds per hill. Satti *et al* (2012) reported that wheat repose angle is very essential for designing the seed box of the planting machine. And they added, that angel ranged between 26-30°. Ibrahim *et al*. (2008) developed the feeding device of seed drill for planting the soaked and hasted seed rice in rows. The results showed that decreasing the weed plants in square meter and increasing the germination percentage by 97% at forward speed of

0.64 m/s. Afify. (2009) developed the feeding device of seed drill to suit planting medical and aromatic seeds in hills and he evaluated the developed seed drill through the terms of four forward speeds and four distances between hills and constant spacing rows of 40 cm. He concluded that the optimum distance between hills was 30 cm to achieve higher seed yield of 815 Kg/fed, lower specific energy consumption of 7.24 KW/ton, production cost of 26.44 L. E/ton and higher germination ratio of 95.37 % with higher field efficiency of 89.41% at forward speed of 3.13 km/h.

The aim of the present study is to fabricated prototype of raised-bed planter for wheat and evaluate the performance of a rationalized power requirement, and operating cost.

**MATERIALS AND METHODS**

**The developed machine prototype was planned to perform two subsequence functions:** (1) Establishing raised bed, (2) Sowing seeds in hills in that beds. It was regarded that this planter can be fabricated from locally available materials and not require sophisticated fabrication techniques. In addition, most of the materials utilized in the fabrication are of the standard sizes. The field experiments were carried out in a private farm at El-Snbelawen district, Dakahlia Governorate after harvesting maize crop.

To achieve the study objective, the following subjects were deduced.

- 1-Laboratory experiments were done.
- 2- Developing the proposal planter unit.
- 3- Evaluate the performance of machine prototype.

**Laboratory experiments: -**

These experiments were carried out to determine the suitable planting disc cells capacity and seeds number in hill. They were done as follows: -

- 1) Average of 50 randomly samples of wheat seeds for six common variates of wheat (Gemeeza 9, Gemeeza 11, Misr 1, Misr 2, Shandweel 1 and Sides 12) (sample=200 seeds) were taken to determine the volume (Cm<sup>3</sup>), weight (g) and bulk density (g /cm<sup>3</sup>) for such wheat seeds variates as shown in Table 1.

**Table 1. main physical properties of common wheat seeds varsities.**

Variety	Gemeeza 9	Gemeeza 11	Misr 1	Misr 2	Shandweel 1	Sides 12
Mass (g)	10.55	11.75	10.15	9.55	8.75	8.61
Volume (Cm <sup>3</sup> )	9.25	10.45	8.95	8.55	7.75	7.56
Bulk density (g/cm <sup>3</sup> )	1.141	1.124	1.134	1.117	1.129	1.139

As shown in table wheat seeds Gemeeza 11 have the maximum weight and volume. So the planting disc cells volume was designed depending on the physical properties of that variety.

- 2) According to the recommendation of the crop Research Institute the planting seeds rate should be 50 Kg/fed, Hills area should be about 200-225 cm<sup>2</sup> and the planting in squares, to produce the highest grain yield Hussein *et al* (2006). Depending on these recommendations the fabricated prototype is planted

wheat seeds in hills in squares shape with space of 15 cm between the rows and between the hills.

**3) The proper seed number in hills was estimated as follows: -**

- 1-Hill area =15x15=225 cm<sup>2</sup> =0.0225 m<sup>2</sup>.
- 2-Cultivated Area in fed = 23x175= 4025 m<sup>2</sup>.
- 3-Hills number/fed = 4025 / 0.0225= 178889 hill/feed.
- 4- The mass of seeds per hill = 50000 / 178889 = 0.28 g/hill. The mass of 200 seed was found to be 11.75g.
- 5-The number of seeds in hill = (200x0.28)/11.75= 5 seeds/hill.

**4) Determiation the seeds cells capacity: -** after determining the seeds number and from the data of laboratory experiments the disc cells volume was manufactured with cell capacity related to the number of required seeds/hill.

**The manufactured planter unit: -**

Figs (1) and (2) show the sketched elevation, and side view and also the photography view of the manufactured planter respectively. It is a mounted planter it can be hitched on the tractor using the three points hitching system. The machine components were manufactured and modified locally at the workshops of El-Zahaira, El-Snbelawen city. It is fabricated with the following main specification: Total weight of (1.96) KN, total length of 1500 mm, total width of 1200 mm, and total height of 1000 mm from the ground surface.

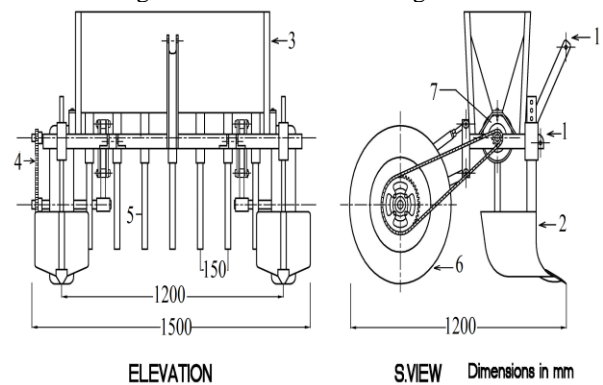

**Fig. 1. the sketched elevation and side views of the manufactured prototype.**

- 1- Hitching system. 2-Establishing raised bed unit.
- 3- Seeds hopper. 4- Chain drive transmission system.
- 5-Planting seeds tubes. 6- Machine wheel.
- 7- Seed metering mechanism.



**Fig. 2. The used tractor equipped with the manufactured planter.**

As shown in Figs (1 and 2) the manufactured prototype is consisting from the main following parts: -

**Frame:** - The frame of the machine was manufactured from 10 cm L shapes iron, with a length of 1400 mm, and width of 400mm. It was provided with some special bearing equipping each of Hitching system, Seeds hopper, establishing raised bed unit, Seed metering mechanism, and transmission system.

**Hitching system:** - A three points hitching system was manufactured locally from 20mm thickness iron. It was designed according to ASAE (1992) The dimensions of that system are: - hitch pin diameter of 25mm, height of 600mm and lower hitch point spread of 650 mm.

**Seed hopper:** - An individual hopper has a prism configuration with trapezoid face shape. It was made from iron sheet with a thickness of 2mm. The maximum capacity of that hopper is about 70 Kg of wheat seed. It was also considered that the inclination angles of the hoper sides were kept at 70° which is more than the repose angles of wheat seeds (26-29°) according to Satti *et al* (2012).

**Establishing raised bed units:** - Two shovel furrow openers units are used for establishing the raised bed. They are fixed on the front of the planter frame and before planting mechanism. The main dimensions of the proper raised-bed are sketched in fig (3).

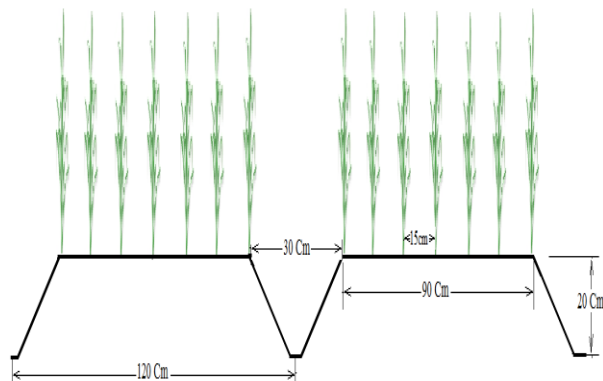

**Fig. 3. Sketch of the proper raised-bed.**

**The seed metering mechanism: -**

Fig (4) shows the seed metering mechanism of the manufactured planter. It consists mainly from three groups of disc cells made from the same material specification (Teflon). The disc diameter of (16 cm), thickness of (5cm) and number of cells (3 cells /disc). The seed cells were fabricated with three different cell capacities to suit different number of seed namely (6,8, and 10 seeds/cell). Each disc group of cells disc consists of seven disc to plant seven row on the raised bed of 120 cm with a space of 15 cm between rows and between the hills. Each disc was covered with iron case has a cylinder shape with internal and external diameters of 16.1and 17cm respectively. Each disc case has two holes the top is used as entry seed from the hopper to the disc cells, while the bottom hole is used as exit the seeds from the disc cells to the seeds planting tube and by consequently in the raised bed. The disc cells were equipped with the moving shaft in the iron case by means of a collecting unit.

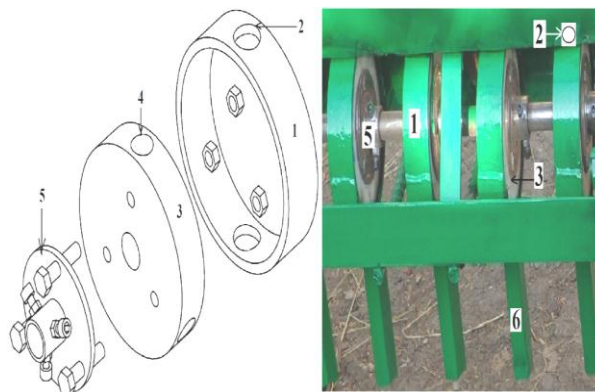

**Fig. 4. The seed metering mechanism.**

**1- Disc case. 2- Seeds entry hole. 3- Disc cells. 4- Seeds cell. 5-Collecting unit. 6-Planting seeds tube.**

**Transmission system:** - It was designed to transmit the motion from the ground wheel (Dia of 51.3 cm) through a sprocket gear of 45 teeth and 20 cm diameter to another gear of 14 teeth and 6 cm diameters that inserts on the shaft of the cell disc (16 cm) with estimated speed ratio (1:3) for the shaft of the cell disc. This ratio was adapted to give equivalent hill number related to the peripheral speed of the ground wheel.

**Source of power:** -A Kubota tractor of 17.91 KW (24hp) with a four-wheel drive system was used as a source of power to accomplish all the experiments of the present study.

**Soil properties:** - The experiments were carried out in silty loam soil texture. The mechanical analysis and soil properties are tabulated in Table (2).

**Table 2. The soil mechanical analysis and soil properties.**

Sample depth	Clay, %	Silt, %	Fine sand, %	Coarse sand, %
0-15 cm	33.5	44.25	19.62	2.63

**The studied variables:**

**The studied variable includes:** - four travel speed (0.76, 1.08, 1.21, 1.46 m/s), Three disc cells capacities (6,8 and 10 seeds) and Two available wheat sowing modes.

**Experimental procedure: -**

The split-split plots experimental design was chosen to carry out the experiments and to analysis the results of the present study. The experimental field area was about 6300 m<sup>2</sup>, this area divided into two main plots the first plot was specialized for carrying out the first sowing mode (M1) that is sowing wheat seed on a pre-established brad bed. The second plot was specialized for carrying out the experiment of sowing mode (M2) that is sowing while simultaneously establish the raised beds. Each of the two main plots was divided into three sub-plots to investigate the effects of three different capacity (C). Each sub-plots divided into four sub sub-plots which involved four forward speeds (0.76, 1.08, 1.21 and 1.46 m/s) with three replicates. The total number of the experiment sub sub-plots were 72 plots, each of 84 m<sup>2</sup> (1.2×70 m).

**Measurements: -**

Two group of measurements were taken to evaluate the performance of the manufactured planter. The first group was to evaluate the machine mechanical performance, while, the second was to evaluate the crop growth performance.

**A: - Mechanical performance measurement**

These measurements were carrying out in field without wheat sowing. Thy were performed to determine each of: - Machinery draught forces (KN), Power required (KW), Actual field capacity (fed/h), specific energy consumption (K.h/fed), and Machinery slip %.

**1-Draft force measurement: -**

The draft forces were measured for the tractor alone, tractor+ sowing machine, the hole combination (tractor+ sowing machine + establishing unit). In each of the above mentioned case a hydraulic dynamometer (Fig.4) was mounted between two tractors (universal 65hp and Kubota tractor 24 hp). The manufactured planter is mounted on Kubota and both were pulled by the universal tractors. Then the readings were recorded by the dynamometer at the different forward speed and the average was calculated. Therefore, draft force was calculated as follows:

**Draft force (KN) = [(0.38 X Reading (bar)]- 0.25-----(4)**

While the specifications of the used hydraulic dynamometer are tabulated in table (3).

**Table 3. The specifications of the used hydraulic dynamometer.**

Total mass (kg)	Length (cm)	Diameter of cylinder (cm)		Reading scale (bar)
		Internal	External	
13	50	3.2	7.7	0 - 60



**Fig. 4. hydraulic dynamometer.**

**2-Power requirements(P):**

The power required (KW) to draw each of the investigated units (tractor, machine prototype, establishing bed unit) estimated according the following formula: -

**P = F x V -----(5)**

**Where:**

P = Power consumption (KW).  
V = Plowing speed (m/s). F = Net draught force (k<sub>N</sub>).

**3-Actual field capacity(Ac): -**

The actual field capacities during carrying out both sowing mode at different operating speeds were estimated according to (Srivastava el al 1993) as follows: -

**Ac(Fed/h) = 1/actual time consumed per operation(h/fed) -----(6)**

**4-Machinery energy consumption (Ec)**

It was estimated for each investigate sowing modes according to (Hunt 1983) as follows: -

**Ec (Kw.h/fed) = P/ Ac-----(7)**

**Where: -**

P = Power requirement(KW),  
Ac= Actual field capacity (fed/h).

**5-Machinery Slip% : -**

The machinery slip % was measured as a function of power loss due to attaching the bed establish unit. However, the slip % was measured in two actual cases under different speeds the first case slip % was measured for the tractor – machinery prototype combination. While the second was measured for that combination as attached with the bed-establishing unit. The slip was calculated from the following equation:

**S = (V<sub>1</sub> - V<sub>2</sub>) / V<sub>1</sub> × 100-----(8)**

**Where:**

S= slip, %  
V<sub>1</sub>=Theoretical speed for both cases.  
V<sub>2</sub>= actual speed.

**B: -Crop Growth Performance measurement: -**

Yield is a function of many factors including number of seeds in hill, germination of hills. So A wooden frame of (1×1 m) is randomly setting with three replicates for each treatment after 15 days from planting. It's easy to count the number of plant per square meter (Cosgrove, 1996). The wheat growth performance was measured as follows: -

**1-number of seed in hill: -**

The number of seeds in hill was accounted randomize hills in each investigated treatment. Measured was done manually direct after sowing.

**2- seed germination in hill: -**

The seed germination ratio (%) in hill of the tested treatment were estimated with three replicates according to (Cosgrove, 1996) as follows:

**Germination ratio (%)= [(N1-N2) /N1] x 100-----(9)**

**Where: -**

N1= the germinated seed number in tested hill.  
N2 = total seed number in the tested hill.

**3-Grain yield (Kg/fed): -**

The grain yield samples were collected three random areas each of (1x1.2) for each investigated treatment. Then the sample were threshed using locally thresher consequently the grain yield was weighted and the average yield were estimated.

**Estimating the cost of tractor and planter machine:**

The cost of operation is divided under two heads known as tractor (cost/hour) and machine (cost/hour).

- 1- The tractor cost/hour = 50 L/h.
- 2- The machine cost/ hour was calculated as flow:

**Machine cost/ hour(M) = (P - s)/H-----(10)**

**Where:**

P is the fabricated price (2000 L).  
S is the salvage (200 L).  
H is the number of working hours.

**The operating cost(L/fed)= (50 +M) / Actual field capacity---(11)**



## RESULTS AND DISCUSSION

The obtained results of the present study could be divided into three subsequent divisions. The first division is to evaluate the mechanical performance to operate the planter under different operating parameters and conditions. The second is to evaluate the crop growth as affected by different design and operating parameters. Finally, the third division is to estimate the net economic benefit, as if the developed planter would be applied instead of the traditional planting techniques.

### Mechanical performance:

The mechanical performance was evaluated from Power requirement, Energy consumption and Machine slip %

### Power requirements: -

The power requirements are shown in Fig (5) as affected by both planting travel speed and establishing bed unit. From the shown data, it can be seen that, the power requirements for the planting machine were varying linearly with the travel speed. As the travel speed increased from 0.76 to 1.46 m/s the power requirements increased from 3.03 to 5.65 kw.

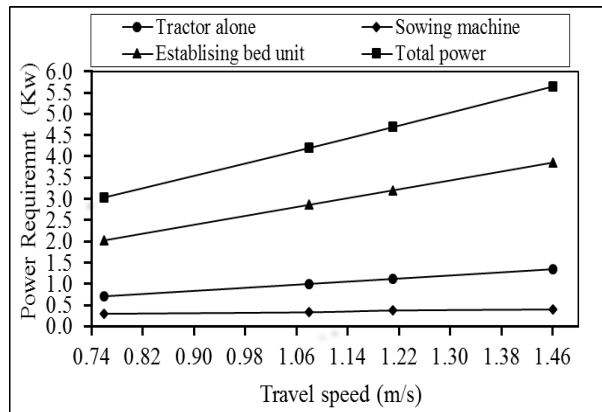

Fig. 5. Effect of travel speed (m/s) and establishing bed unit on required power (Kw)

Also from the shown data, it can be seen that, the power requirements for sowing machine were varying with the establishing bed unit. As the using establishing bed unit the power requirements increased from 1.4 to 2.99 Kw. As a result, for using the establishing bed unit witch required the draft force more than sowing machine and tractor alone.

### Energy consumption: -

The energy consumptions are shown in Fig (6) as affected by both planting travel speed and sowing mods. From the shown data, it can be seen that, the energy consumptions for the planting machine were varying linearly with the travel speed. As the travel speed increased from 0.76 to 1.46 m/s the energy consumptions increased from 2.06 to 3.01 (kw.h/fed)

While, using the sowing mode M2 (that is sowing while simultaneously establish the raised beds) instead of M1 (that is sowing wheat seed on a pre-established brad bed). Increasing energy consumption from 1.33 to 3.01 (KW.h/ fed). As a result, for increasing required power, slip % and decreasing actual field capacity. On the base of the energy consumption (kw.h/fed), it can be seen

that, using the sowing mode M1 saved the energy consumption.

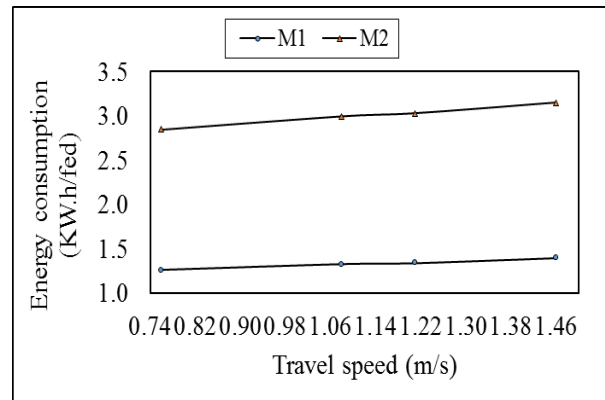

Fig. 6. Effect of travel speed (m/s) and sowing modes on energy consumption (KW.h/ fed).

### The tractor drive wheel slip (%)

The slip data are presented as the planter was planting at four different speeds and Two sowing modes. The average slip data are shown in Figs, (7). It can be seen that increasing operating travel speed gave a sensible increment rates in slip % for example the slip % increased from 9.38 to 12.55 % as the travel speed increased from 0.76 to 1.46 m/s by increment of 33 %. While using sowing mode M2 instead of sowing mode M1 increase slip % from 9.94 to 12.56 %. As a result, for increasing the draught force four sowing while simultaneously establish the raised beds instead of sowing wheat seed on a pre-established brad bed.

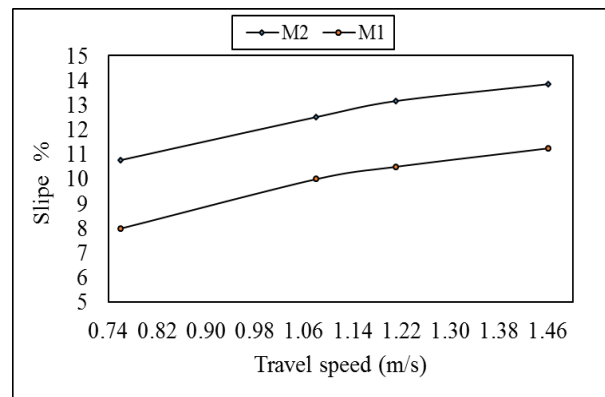

Fig. 7. Effect of travel speed (m/s) and sowing modes on slip %.

Owing the slippage should be less than 15% for the combination of the planter tractors. the following conclusion may be drawn. The suitable forward speed for the developed planter may be ranged from 0.76 to 1.21m/s for carrying out the planting operation.

### Effect of the studied parameters on crop growth.

The means values of the crop growth factors were analyses to determine the best parameters and the results as the following: -

#### 1- Number of seeds in hill: -

The results of seeds number cleared that there are no obvious effects of the two sowing mode on the number of seeds in hill. So, fig (8) shows the effects of travel speed (m/s) and cells capacity on the number of seeds in hills.

The figs showed that, at the travel speed of 0.76 (m/s) the actual number of seeds in hill are equals to the determination number of the cells seed at any cells capacity but by increasing the travel speed from 0.76 to 1.46 (m/s) the seeds number decreased by 10.8%. This may be due to the increasing of travel speed decreasing the required time to fill up the cells with the required seeds number. However, the maximum of seeds number in hill was recorded with cells capacity3 (10 seeds) at 0.76 (m/s) travel speed. While minimum mean seeds number in hill was produced by cells capacity1 (6 seeds) at 1.46 (m/s) travel speed.

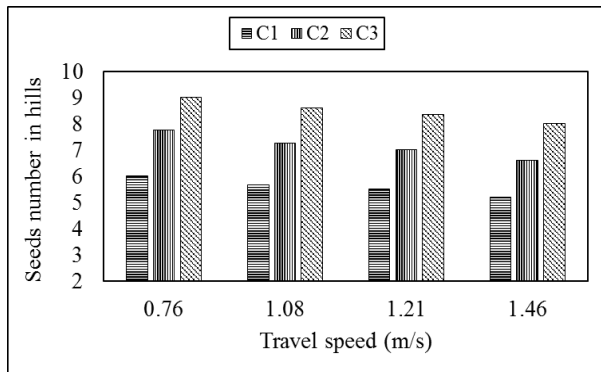

Fig. 8. Effect of travel speed (m/s) and cells capacity on the number of seeds in hills.

**2-Germination of hills seeds % :-**

Data concerning germination hills are showed in Fig. (9). Analysis of the data revealed that difference was noticeable for germination percent between the two sowing mode (M1 and M2). Maximum germination percent were 97.78% for M1 with 1.21 (m/s) travel speed while the corresponding percent for M2 was 82.22% with 0.76 (m/s) travel speed. At the same time, the minimum germination percent were 96.29% for M1 with 1.46 (m/s) travel speed while the corresponding percent for M2 was 76.67% with 1.26 (m/s) travel speed. Also the data cleared that, M2 decreasing the germination present by range from 15.56 to 19.62%. That decreasing of the germination present by reason of formatting a heavy cover from soil witch covered the hills and consequence leads to seeds death and not germinations especially on two side of the raised beds. Finally, from the view point of germination ratio it may be recommended that the use of developed planter should be at forward speed 1.21 (m/s) with M1(sowing wheat seed on a pre-established brad bed).

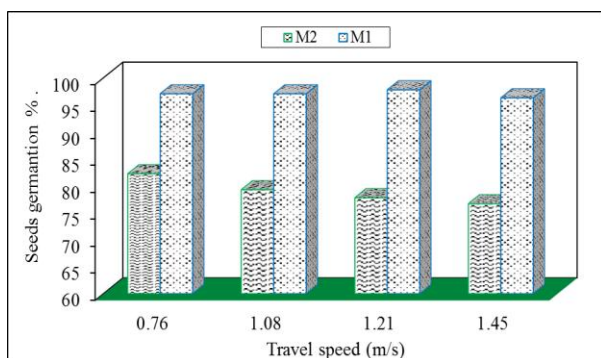

Fig. 9. Effect of travel speed (m/s) and sowing modes on seeds germination %.

**4-Grain yield (ton/fed): -**

Data concerning grain yield are showed in Fig (10). Analysis of the data revealed that. Maximum grain yield (2.9 ton/feed) was produced by using cells capacity2 (8seeds) with 1.21 (m/s) travel speed followed by (2.89 ton/feed) from using cells capacity3 (10seeds) with 1.46 (m/s) travel speed. While, the minimum grain yield (2.76 ton/feed) was produced by using cells capacity3 (10 seeds) with 0.76 (m/s) travel speed with sowing mode M1.

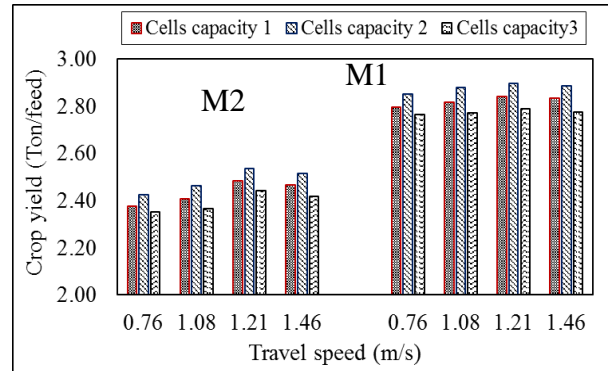

Fig. 10. Effect of travel speed (m/s), two sowing modes and disc cells capacity on crop yield (ton/feed).

While, the corresponding data for M2 were: - The maximum grain yield (2.54 ton/feed) was produced by using cells capacity2 (8seeds) with 1.21 (m/s) travel speed followed by (2.51 ton/feed) from using cells capacity3 (10seeds) with 1.46 (m/s) travel speed. While, the minimum grain yield (2.35 ton/feed) was produced by using cells capacity3 (10 seeds) with 0.76 (m/s) travel speed. Comparing the two sowing modes cleared that, M2 decreasing the yield by 13.78%. As a result, for decreasing the number of germination hill.

At the same time increasing the travel speed from 0.76 to 1.46 (m/s) the grain yield increased by 1.42%. That by reason decreasing the number of seeds in hill which leads to increasing the plants growth.

Finally, from the view point of grain yield it may be recommended that the use of developed planter should be at forward speed ranges 1.08 to 1.46 (m/s) with cells capacity2 (8seeds).

**Estimating the costs of using the fabricated planter.**

The operating costs of the fabricated planter with the Two sowing mode were calculating by using equations from 10 and 11. The maximum operating cost of 59LE/fed was with using M2 while at using M1 the corresponding value was 44 LE/fed. In comparison, the manual planting for one feedan required from five to six labor the salary of one labor is 30 LE So, the cost of manual planting of the Feedan was ranged from 150 to 180 LE/fed. Finally, using the fabricated planter decreased the cost by range from 91 to 121 LE/fed.

**CONCLUSION**

From the obtained results in the present study, it can be seen that the deformed raised-broad beds, using the developed machine can be efficiently utilized as

appropriate sowing technique for growing of wheat crop in Egypt.

The data evaluated the developed machine performances, concluded, that the best planting performance was accomplished using forward travel speed of 1.21 (m/s), and metering cells capacity of (8seeds). Whereas, under these operating conditions lower energy consumption of 3.01 kw.h /fed, higher grain yield of 2.9 (ton/fed), production cost of 59 LE/fed and higher germination ratio of 97.78% % were achieved compared to the other investigated operational parameters.

## REFERENCES

Abou Sabe A.H (1956) possibility of using the farm machines in Egyptian agriculture. Lecture No. 9 Alex.: 1-11.

Afify. M. K. (2009) Development of seed drill feeding device to suit planting in hills. Misr J. Ag. Eng. 26(1): 561-579.

ASAE standard (1992). Joseph, At. MI 49085.

Cosgrove, D. (1996). Alfalfa Management Guide. University of Wisconsin-River Falls, 1-68.

Hussein, H.F; Faida. A. A Sharara and S.A. Ahmed (2006) Effect of sowing methods and weed control treatments on wheat yield and associated weeds in sandy soil. Egypt. J. of Appl Sci.21 (3) :177-192.

Ibrahim, M.M.; H. N. Abd El-Mageed and T. H. Abd-Alla (2008). Development and evaluation a small machine for soaked rice direct planting. Misr J. Ag. Eng. 25. (3): 655-676.

Jat, R.S; A.C. Shivran and J.P Mehta (2004). Growth and yield of wheat (*Triticum aestivum* L.) as affected by weed control and method of sowing. Res. on crop, 5(1): 18-21.

Lack. Sh (2012). The effects of seed number per hill on grain yield and source-sink relations of three rice cultivars. African Journal of Agricultural Research 7(1). 43-50.

Roth. C.H, Fischer R.A. and Meisner. C.A. (2005) Evaluation and performance of permanent raised bed cropping systems in Asia, Australia and Mexico edited ACIAR Proceedings No. 121.

Satoshi H; Akihiko K, and Junko Y (2000). Effect of planting density on grain yield and water productivity of rice (*Oryza sativa* L.) Grown in flooded and non-flooded fields in Japan. Crop Science Society of Japan.

Satti, H. Y, Qingxi L, Jiajia Yu, and Dali He (2012) Design and test of a pneumatic precision metering device for wheat. CIGR Journal 14,1 March:16-25.

Srivastava, A. K.; C. E. Goering and R. P. Rohrbach (1993). Engineering principles of agricultural machines. ASAE Textbook No. 6, Published by the ASAE.35-38

Swelam, A. (2015). Development of a cost-effective raised-bed machine for small-scale farms to improve land and water productivity in the Nile Delta of Egypt. Science Impacts, Oct,4.

Tanveer, S.K; I. Hussain; M. Sohail; N.S. Kissana and S.G. Abbas (2003). Effect of different planting methods on yield and yield components of wheat. Asian j. of plant Sci; 2 (10): 811-813.

UNDP (2013) Raised-bed planting in Egypt: an affordable technology to rationalize water use and enhance water productivity. Science Impacts Oct,4.

Wang, F, Wang, X. and Sayre, K.D. 2004. Comparison of conventional, flood irrigated, raised bed planting for winter wheat in China. Field Crops Research 87: 35-42.

## تصنيع نموذج أولى لزراعة بذور القمح على مصاطب محمود على عوض محمد مركز البحوث الزراعية – معهد بحوث الهندسة الزراعية

تعتبر طريقة الزراعة على مصاطب من أحدث الطرق الزراعية التي أوصت بها الدراسات العلمية الحديثة للنهوض بالمحاصيل الزراعية وبخاصة محصول القمح، حيث يزرع القمح على قمة المصطبة في جور لما لها من نتائج فعالة في زيادة الإنتاج وتوفير مياه الري. ولكن تواجه هذه الطريقة مشكلة عدم توافر آلات زراعية مناسبة وإرتفاع تكلفة الأيدي العاملة. لذا كان هذا البحث بهدف تصنيع وتقييم نموذج أولى لزراعة القمح في جور على مصاطب مع إمكانية إقامة المصاطب في نفس وقت الزراعة من عدمه. وقد تم تصنيع النموذج موضوع البحث من خامات محلية في الورش المحلية بمدينة السنبلوين. وقد تم اختبار أداء هذه الآلة تحت تأثير المتغيرات الدراسية التالية: ١- أربعة سرعات تقدم امامية وهي (٠.٧٦، ١.٠٨، ١.٢١، ١.٤٦ م/ث) ٢- ثلاثة ساعات حجمية لخلايا قرص الزراعة وهي (٦، ٨، ١٠ بذرة/خلية). ٣- ميعادان لتشكيل المصطبة (قبل الزراعة - في نفس الوقت مع زراعة البذور). وقد تم تقييم أداء الآلة موضوع البحث من خلال محورين أساسيين: -المحور الأول: - يتعلق بتحديد متطلبات القدرة والطاقة اللازمة لتشغيل الآلة ونسبة الإنزلاق لعجل الجرار والتكلفة الالية لزراعة الفدان بالجنيه. المحور الثاني: - يتعلق بدراسة مواصفات نمو النبات من حيث عدد البذور بالجورة، نسبة إنبات الجور، انتاجية محصول الحبوب (طن/فدان). تحققت أفضل نتائج الأداء للآلة المطورة عند استخدام سعة حجمية لخلايا قرص الزراعة مقدارها (٨ بذرة/خلية). ومع متوسط سرعة تقدم امامية مقدارها ١.٢١ م/ث وذلك عند تطبيق نظام تشكيل المصاطب اولاً ثم بذر البذور لاحقاً. حيث تحقق انسب معدل استهلاك طاقة نوعية للآلة المطورة مقدارها (٣.٠١ كيلو. وات. ساعة/فدان) بتكلفة الية للزراعة مقدارها (٥٩ جنيه/فدان)، وتحققت اعلى انتاجية محصول حبوب مقدارها (٢.٩ طن/فدان) ونسبة إنبات ٩٧.٧٨% لذا يوصى باستخدام الآلة في مدى تقدم امامية من ١.٠٨ إلى ١.٢١ م/ث مع استخدام خلايا قرص الزراعة التي تسع ثمانية بذور ومع إقامة المصاطب قبل الزراعة.